

# EL80A, EL80AF

## MOTOR OPERATED EXTERNAL VENETIAN BLIND 80 MM SLATS WITH SIDE GUIDING CABLES

EL80A : beaded 80 mm slats

EL80AF: flexible 80 mm slats

### Description

- Roll formed zinc-plated steel U-shaped head rail 57 x 51 mm
- Thermally protected 230 V motor, dust and splash waterproof according to IP54
- Positive tilting mechanism to prevent slat movement by wind
- Lowering with slats closed, raising with slats 45° open
- Roll formed coil coated 80 mm slats of partly recycled aluminium
- Natural anodised or powder coated extruded aluminium bottom rail 80 x 22 mm
- Tensioned stainless steel cable  $\varnothing$  3 mm with transparent Nylon jacket
- Black bottom rail end caps, lift tape and Aramid reinforced polyester ladder cords
- UV and weather resistant components of mixed composition
- Wind stable as further determined by size and controls

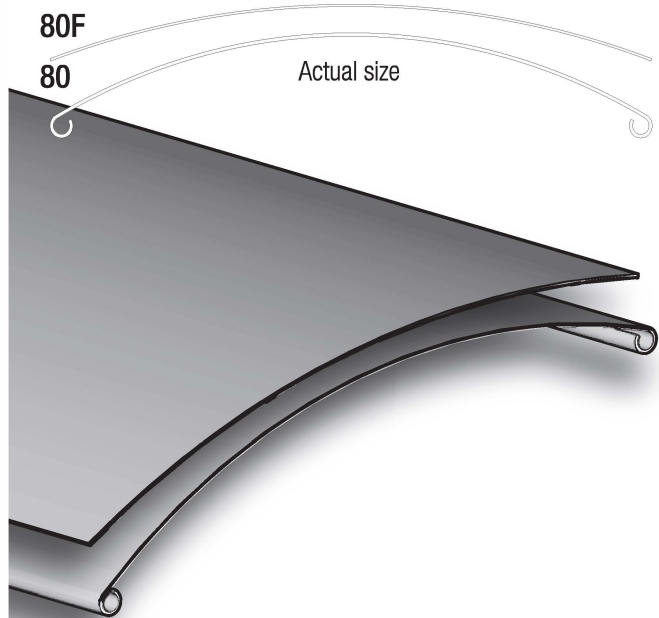
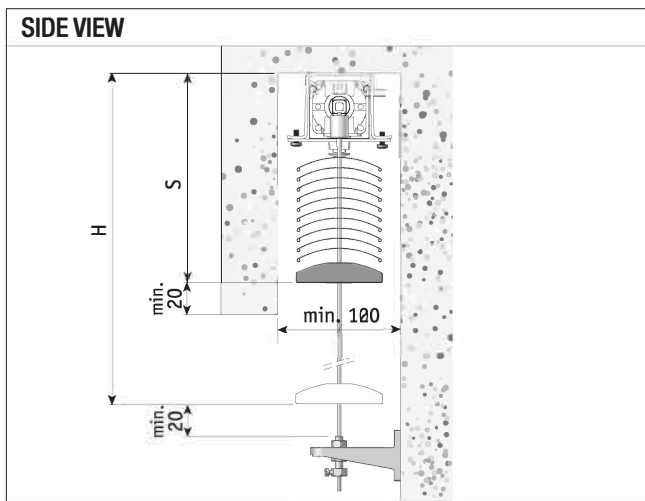
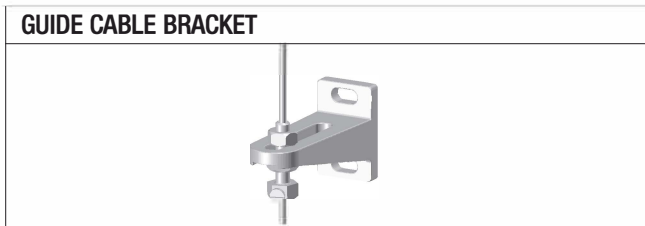

		width		height max. (cm)	surface max. (m <sup>2</sup> )
		min. (cm)	max. (cm)		
Single	EL 80 A	51	500	450	16
	EL 80 AF	51	500	400	16
Group	EL 80 A		1000	450	20
	EL 80 AF		1000	400	20

STACKING HEIGHT (MM) (intermediate blind heights on page 85)								
Blind height	Stacking height S 80A	Stacking height S 80AF	Blind height	Stacking height S 80A	Stacking height S 80AF	Blind height	Stacking height S 80A	Stacking height S 80AF
1000	173	133	2500	263	185	4000	354	222
1500	202	155	3000	294	197	4500	387	X
2000	234	172	3500	324	210			

# OPTIONS EL80A, EL80AF

## GUIDE CABLE BRACKETS

4 sizes (X, mm);  
 27 - 73  
 60 - 105  
 67 - 133  
 124 - 173

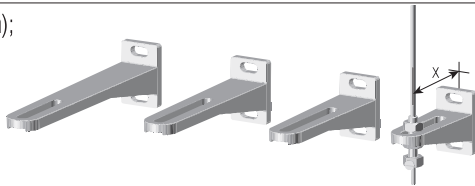

## GUIDE CABLE BRACKETS, IDEFIX

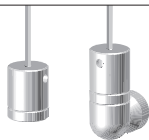

## HEAVY DUTY CABLE BRACKETS

Shapes and sizes according to customer specifications  
 (X=max.500)

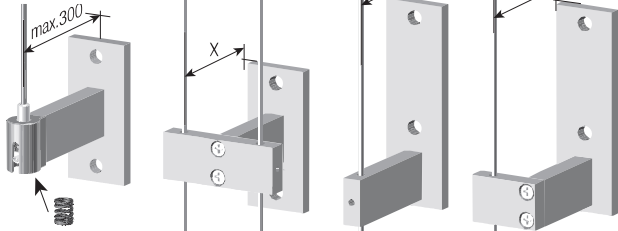

## PELMET

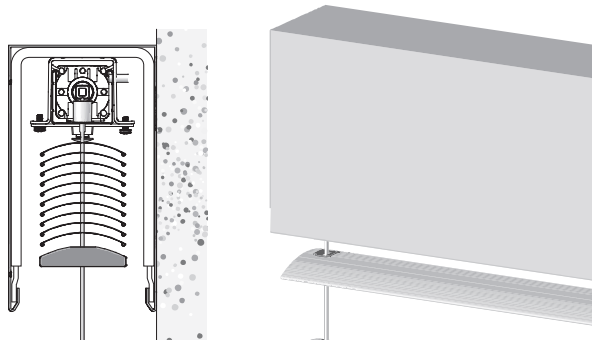
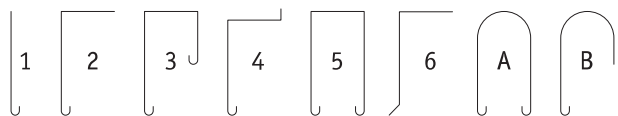

## 40° TIMER

Standard;  
 lowering with closed slats

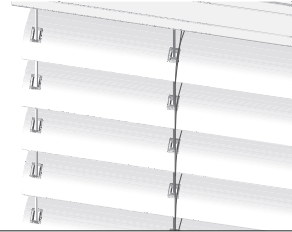

40° Timer;  
 lowering with slats 40° open

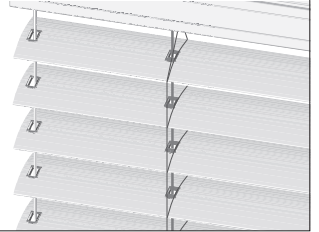

## HEAD RAIL

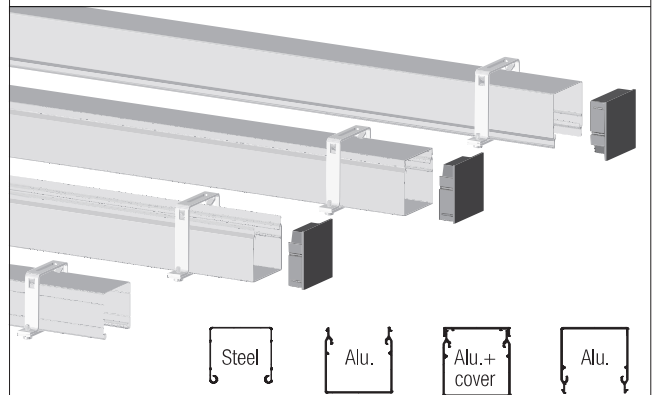

## COUPLING



## FURTHER OPTIONS (Additional information on page 81)

- Quick raise system for emergency situations (EL80AN, EL80AFN)
- Dual Light Control
- Slow motion motor for more precise slat tilting
- Beaded slat with inserted black seal to reduce contact noise and light leakage
- Perforated slats
- Additional guiding cable(s)
- For possible motor controls see separately available documentation